

Nom	Surface
CH.2	9.69 m <sup>2</sup>
CELLIER	4.47 m <sup>2</sup>
DEGT.	2.79 m <sup>2</sup>
CH.3	9.13 m <sup>2</sup>
CH.1	10.07 m <sup>2</sup>
S.d.Bains	6.16 m <sup>2</sup>
SEJOUR CUISINE	47.58 m <sup>2</sup>
Total général: 7	89.89 m <sup>2</sup>

Surface au sol: 123.20m<sup>2</sup>  
 Surface du vitrage: 15.04m<sup>2</sup>  
 89.89m<sup>2</sup>:6=14.99m<sup>2</sup>

Surface SDP	
Nom	Surface
Rez de chaussee	93.67 m <sup>2</sup>

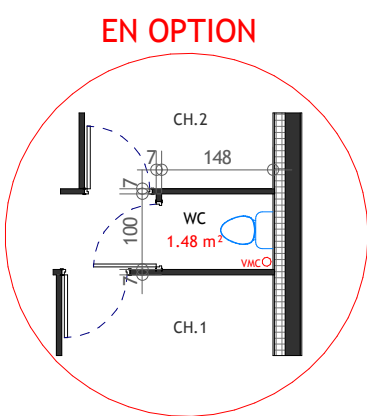
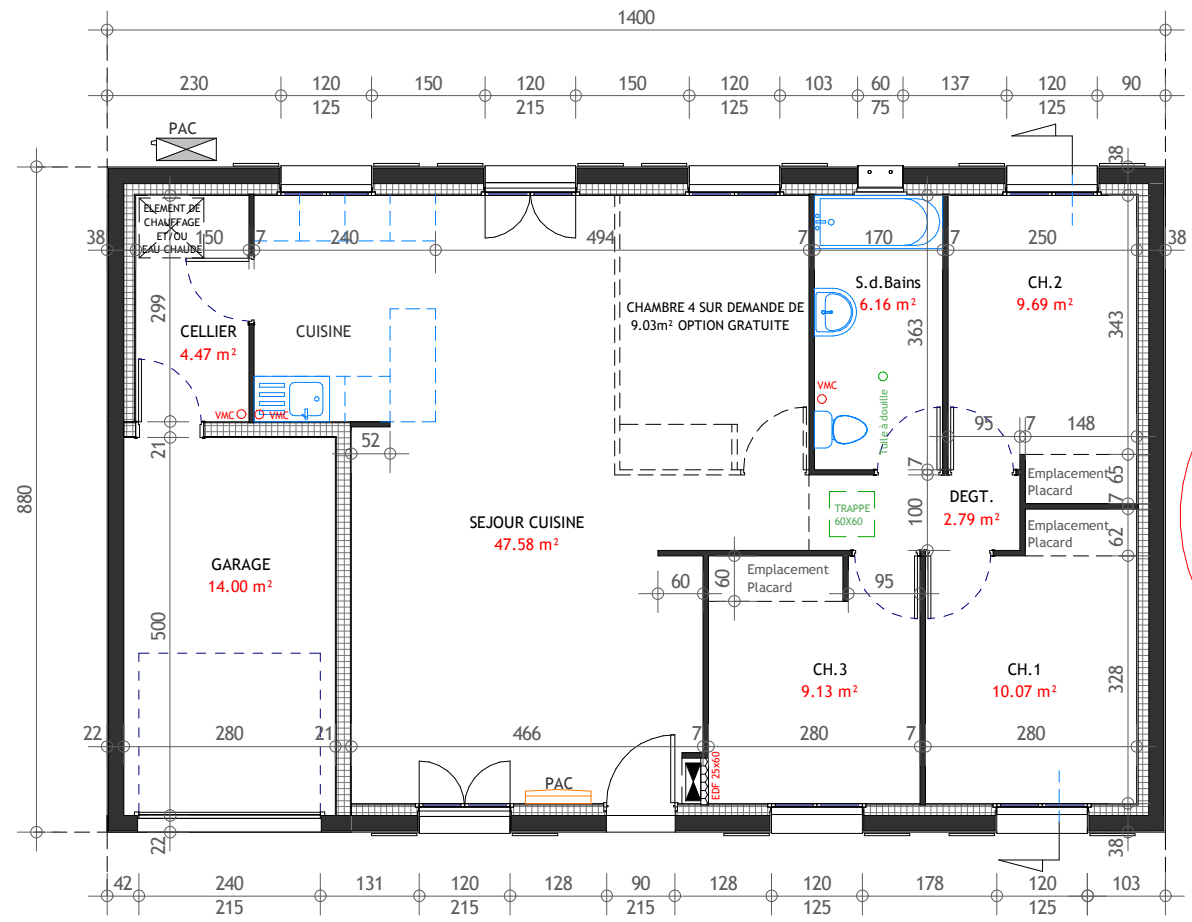

WC indépendant possible en option avec supplément



RDC Façades Coupe Pignon 35°

Ech 1 : 100  
 Date 12/01/2018  
 Dessiné par .

PARIS 3.090 GI

